

Recommend PCB layout
(Tolerance:±0.05)

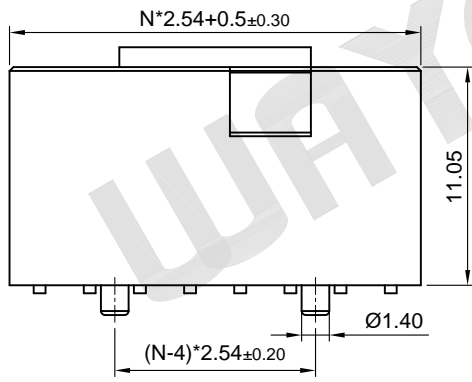

N=No.of contacts/2

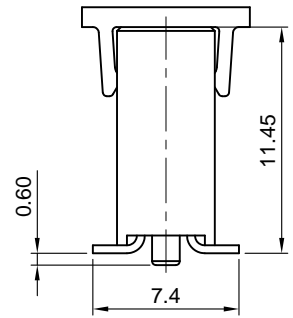

1. MATERIAL
 - 1.1 INSULATOR: THERMOPLASTIC (UL 94V-0).
 - 1.2 CONTACT MATERIAL: COPPER ALLOY.
2. SPECIFICATION
 - 2.1 CURRENT RATING: 1.5 Amp.
 - 2.2 INSULATION RESISTANCE: 1000mΩ Min.
 - 2.3 DIELECTRIC WITHSTANDING: 600VAC.
 - 2.4 CONTACT RESISTANCE: 20mΩ Max.
 - 2.5 OPERATING TEMPERATURE: -40°C TO +105°C.
3. PLASTIC WITHSTAND TEMP
 - 3.1 MAX PROCESSING TEMP:
 - 180°C FOR 30-60 SEC; (200°C FOR 5-10 SEC.) - PBT
 - 230°C FOR 30-60 SEC; (260°C FOR 5-10 SEC.) - PA6T

FH 254 - XXX - XXX GX - 27

Gender	Plating
P=Pin Header F=Female Header	G0: Gold Flash G2: 1U" Gold G3: 3U" Gold G4: 5U" Gold G5: 10U" Gold G6: 15U" Gold SN: Tin
Pitch	Packing Style
0.80=080 1.00=100 1.27=127 2.00=200 2.54=254	1. Loose in Bag 2. Tape & Reel 3. Tube
No. of PINS	Insulator Material
1 x 01 ~ 1 x 40 PINS 2 x 01 ~ 2 x 40 PINS 3 x 01 ~ 3 x 40 PINS	1: PBT 2: PA6T 3: PA9T 4: LCP
Connector Type	
S=Straight R=Right Angle M=SMT	

PRODUCT TITLE:		2.54mm Pitch, SMT, H=11.45mm, 2 Row	
UNLESS OTHERWISE SPECIFIED TOLERANCES	SCALE: 1/1	UNIT: mm	FH254-2XX-MXXG0-27
	SIZE: A3	PAGE: 1 OF 1	
DECIMALS:	ANGLES:	WAYCONN ELECTRONICS	
X :±0.5	X :±6°		
X.X :±0.3	X.X :±3°		
X.XX :±0.2	X.XX :±2°		